

FLUSHED WITH SUCCESS

C. W. Hirt and A. Y. Souders

May 1991

INTRODUCTION

Everyone encounters a toilet (or loo) on a daily basis, but few of us ever stop to think how these devices actually work. In the most common designs five to six gallons of water are released into the toilet bowl, usually but not always, with a swirling motion. The water level first rises rapidly and then falls somewhat more slowly until air is ingested into the bottom drain.

If the toilet is well designed, its flushing action will be powerful enough to remove solid waste without splashing, it will leave a clean bowl and it will not use an excessive amount of water. An efficient toilet will also be recharged in a short time, ready for further use.

Casual observations of the toilet facilities at home, at work and in local businesses will reveal the wide variety of waterflow configurations in common use. Some toilets have bottom inlets while others have inlets only around the top of the bowl. Other designs have horizontal inlets directed either rearward or forward, with or without an offset with respect to a central drain. Most toilets, in fact, use a combination of these flow configurations.

Manufacturers must produce toilet bowls of different shapes and sizes to please a wide range of public taste. Unfortunately, since optimum design conditions can usually be determined only by costly experimentation, manufacturers do not always achieve ideal conditions in each new design.

These observations suggest that any technique to improve the design process, which would be faster and cheaper than direct experimentation, would provide a manufacturer with a competitive edge. In this note we argue that computational modeling is such

a technique. Our argument is presented in the form of a demonstration. Using the commercial computer program, FLOW-3D, we have modeled the flushing of a simple toilet configuration. Our toilet is an imaginary design patterned after several actual toilets but not representing any known toilet.

In the next section we describe the observations that led to our toilet's design. This is followed by a discussion of specific computational results. Finally, a summary discussion is given of the lessons learned and the prospects for future computational analysis.

PROBLEM DESCRIPTION

A quick review of encyclopedias, plumbing manuals and "How Things Work" books reveals few details about the hydrodynamics of toilets. One essential element of many toilets, however, is a siphon whose action can be determined by a few simple experiments.

Basic Observations

If water is added slowly to a toilet bowl, the water level will stay close to some equilibrium level, indicating an escape of water into the drain. On the other hand, if water is added rapidly and in sufficient quantity to the bowl, the toilet will flush. That is, it will empty until air is ingested from the bowl into the drain.

These experiments suggest that the drain leaving the toilet has an inverted U or siphon shape. One side of the siphon is connected to the toilet bowl and is full of water. The other side leads to a drain pipe connected to a sewer and is empty. When water is added to a toilet bowl, raising the level of water in the bowl, hydrostatic forces will attempt to raise the water level in the siphon by an equal amount. This causes water to spill over into the drain side of the siphon and explains why a slow addition of water to the bowl can never raise the water level much above its equilibrium height. When, however, the water is added sufficiently fast, the siphon will completely fill (i.e., it is primed) and the toilet flushes.

Many toilet designs introduce a swirling flow in the bowl in an attempt to increase the cleansing action of the water. A nonuniform bowl depth may also contribute to sloshing and, hence, to an increase in cleansing. Some designs use a bottom fill that helps to raise and disperse solid waste before removing it, while others use a strong jet-like flow that pushes solid waste directly into the drain. In the following computational model we have elected to use a combined bottom fill with a horizontally-offset side fill that adds swirl to the bowl.

Geometric Model

Our model bowl consists of the lower halves of two ellipsoids. Both ellipsoids have the same cross section at their midplanes where they are joined together. In the direction normal to the joining, i.e., in the front to rear direction of the toilet, the semi-major lengths of the ellipsoids are different - the ellipsoid defining the front portion of the bowl having a longer length than that of the rear ellipsoid. This may be seen from the central cross section plot of the toilet (and initial fluid configuration) shown in Fig. 1.

Since the semi-major axes of the ellipsoids are 8 and 4 inches, respectively, the front-to-back bowl length is 12 inches at the top of the bowl. The top bowl width is 9 inches and the maximum bowl depth is 5 inches.

At the bottom of the bowl, where the two ellipsoids are joined, a vertical drain pipe has been inserted that has a circular diameter of 2 inches. This drain extends 2 inches below the bottom of the bowl.

Attached to the vertical drain is a horizontal pipe of rectangular cross section, whose cross-sectional area is the same as that of the 2 inch circular drain. The width of this rectangular drain segment matches the diameter of the circular pipe (therefore, the pipe has a width of 2 inches and a height of 1.57 inches, giving a flow area of π square inches). Finally, there is a siphon consisting of two vertical segments of rectangular pipe connected at their tops with a 180-degree, circular elbow pipe. The elbow has the same rectangular cross section as the rectangular pipe segments it connects.

A horizontal inlet pipe enters the left side of the computational region ("left" when looking at the bowl from front to rear). This inlet has a 90-degree bend that sends its flow into the bowl at a location left of the centerline and directed toward the front of the bowl. Because of the offset, this flow generates a swirl in the bowl while it is filling.

The bottom of the vertical, circular drain is also an inlet port for the filling phase of a flush cycle. This port is shut, however, except when water is being introduced into the bowl. Water is allowed to drain from the system through a specified pressure outlet located at the bottom, backside of the siphon (the bottom of the siphon is closed). Figure 2 shows a perspective view of the complete geometric arrangement.

Numerical Model

Physical units for the model were taken to be length in inches, time in seconds and pressures in pounds per square inch (psi). The origin of the computational coordinate system was selected to simplify the definition of the solid modeling functions. The horizontal origin (x,y) was taken to be the center of the drain pipe in the bottom of the bowl. The vertical origin was at the top of the region modeled and corresponds to the vertical midplane of the ellipsoids making up the bowl. This placement of the vertical origin means that all z coordinates are negative, but this introduces no difficulties.

The computational grid used to cover the geometric model consists of 30 cells in the x direction (front to rear), 16 cells in the transverse direction (side to side) and 14 cells vertically, Fig. 3. The total number of cells, including boundaries is 9504.

Specified velocity boundary conditions were used at the bottom and side inlets to the bowl. At the bottom the flow is ramped from zero up to 15.0 in/s in 0.1 s and remains at that value for 2.0 s. Between $t=2.1$ and $t=2.2$ s this flow was then ramped back to zero.

Inflow at the side was also ramped up from zero to 15.0 in/s in the first 0.1 s of the problem. This inlet, however, continued to flow at that rate until $t=2.5$ s and then was ramped to zero in the following 0.1 s. A longer side inflow time was selected to increase swirling in the bowl.

Outflow, downstream of the siphon, was through the back boundary of the computational region. This boundary was given a specified pressure condition. Because the siphon was found to be difficult to prime, we lowered the outlet pressure for a short time following the filling. We did this instead of altering the inflow volume and flow rate because we didn't want to engage in multiple exploratory calculations to determine what volume and flow rate were needed. The outflow pressure was reduced below atmospheric pressure from 0.0 psi at $t=2.1$ s to 0.2 psi at $t=2.2$ s, held at that value until $t=2.5$ s and allowed to return to atmospheric pressure by $t=2.6$ s.

When this project was started, we didn't know that the typical amount of water in a flush was as high as 5 or 6 gallons. Our model is initialized with 0.28 gal and only 0.6 gal is added through the two inlet ports. This explains why our siphon was difficult to prime and why the swirling in the bowl is not very intense (see below). This also explains why our flush period (time to air ingestion) of approximately 5 seconds is low compared to most toilets.

The working fluid was water, except that we have ignored viscosity (because the Reynolds number for the flow is large) and have ignored surface tension (because the Weber number is large). Additionally, such complications as turbulence and air entrainment into the water have also been neglected.

For initial conditions, the water level was set to the maximum height possible such that no water would flow to the drain side of the siphon (see Fig. 1). The water was assumed at rest in hydrostatic equilibrium. Marker particles were initialized in the lower portion of the bowl, but not in the vertical drain pipe leaving the bowl. These particles do not affect the flow in any way; they are purely massless markers. We have, however, allowed the particles to diffuse in addition to moving with the mean flow. This diffusion may be thought of as the motion of particles by random turbulent eddies.

A complete input file used by FLOW-3D for this computation is given in Fig. 4. This file contains all physical property data, mesh and obstacle descriptions, boundary and initial conditions, as well as all computational parameters controlling the operation and output of the code.

The entire problem was run to a time of $t=6.0$ s, which consumed about 40 hours of CPU time on a MicroVAX II computer. This is a slow machine by today's standards. For example, the DEC Station 3100, which now costs about the same as the MicroVAX did when it was new, would only take about 4.0 CPU hours. A CRAY supercomputer, on the other hand, would require much less than an hour to complete the calculation, and would also be able to handle significant increases in model resolution.

COMPUTATIONAL RESULTS

A sequence of plots showing the water distribution in the toilet every second between 0 and 5 seconds is given in Fig. 5. These plots show the three-dimensional contour surface of fluid fraction equal to 0.5 and may be interpreted as the free-surface configuration.

The maximum water height in the bowl is reached at about $t=2.0$ s. For the plots we see that the downstream side of the siphon does not fill until $t=3.0$ s. At this time the water level in the bowl has already started to decrease. By $t=4.0$ s the water level is below its initial height, and by $t=5.0$ s air has been ingested into the bottom drain pipe. At $t=5.0$ s there are a few bits of fluid remaining in the bowl and in the side inlet pipe.

Another view of the flush is provided in Fig. 6. Here we show vertical cross section plots at the same times as in the previous figure. The dimpling of the free surface above the drain at $t=4.0$ s and final ingestion of air by $t=5.0$ s are more clearly seen in these plots.

Neither of the previous plots shows the swirling flow in the bowl, which is shown in Fig. 7. Only three plot times are displayed because the fluid starts and ends below the vertical height where these plots are recorded (at $z=-3.5$ in.) At $t=2.5$ s

the flow is dominated by the inlet jet. At $t=3.0$ s, after the inlet flow has stopped, a swirl is clearly evident. By $t=3.5$ s the swirl is seen to be slightly more intense over the drain. It is evident, however, that the swirl velocity remains relatively small compared with the inlet and drain velocities. Presumably this is a consequence of the small amount of water added to the bowl.

Figure 8 displays the final sloshing of the water remaining in the toilet after the siphon is no longer primed. Air, in fact, reaches the top of the siphon shortly after $t=5.0$ s. In Fig. 8 we see from the first plot at $t=5.5$ s that water has already sloshed into the bowl and is returning back toward the siphon. By $t=6.0$ s water in the drain is trying to approach an equilibrium, but there is still a small amount of liquid in the bowl with a significant slosh velocity.

Finally, in Fig. 9 are shown plots of marker particle distributions. The first plot is the initial configuration. Particles (about 650 in number) are initialized with a random number generator so that they do not line up along straight lines.

After 2.0 seconds of time, when the bowl is near its maximum filling, we can see that the particles have been lifted up into the bowl as a result of flow coming from the bottom inlet. No particles are in the drain system at this time. A second later (at $t=3.0$ s) when the siphon is primed and a strong flush has commenced, many particles have left the bowl and entered the drain system. Those particles still in the bowl are rather uniformly distributed.

SUMMARY COMMENTS

The example toilet flush presented here is based on an artificial toilet design. Nevertheless, it possesses many features found in typical toilets, such as multiple inlets, a siphon, a variable depth bowl and a swirl flow component. Furthermore, our model toilet operates in a manner similar to real toilets.

A computation of one complete flush cycle has been presented. In the course of obtaining these results it was discovered that priming the siphon took some doing. It was subsequently discovered that we probably had not used enough water. In this respect our calculations appear to be realistic. This is one area, then, where computer simulations would be useful in helping to design the size and location of flow inlets.

Another finding was that the swirl velocity was not particularly large. A completely different inlet design is needed to increase the swirl, or the inlet used must be given a larger velocity, be relocated or redirected.

Marker particle distributions were seen to exhibit a reasonable behavior in terms of the filling and draining portions of the complete flush. Most interesting, of course, would be a capability in which the particles could be used to represent solid waste. This capability requires a major modification to FLOW-3D to model coupled, two-phase flows, but it is one that we intend to undertake in the near future. In summary, then, FLOW-3D has been shown capable of modeling the fluid dynamics associated with the flush of a typical toilet. While this is an ordinary everyday flow problem, it is far from simple because it involves complex geometry, free fluid surfaces and strong non-linear flow processes.

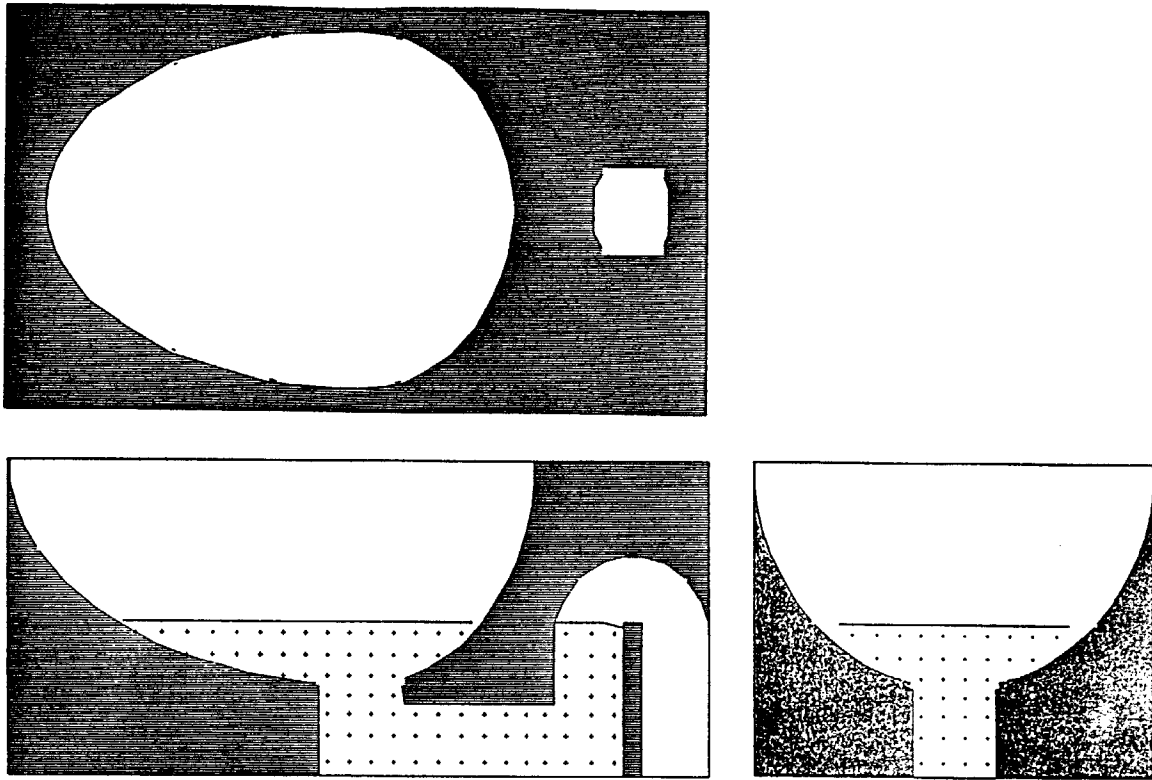

Fig. 1. Cross sections showing loo geometry and initial fluid location.

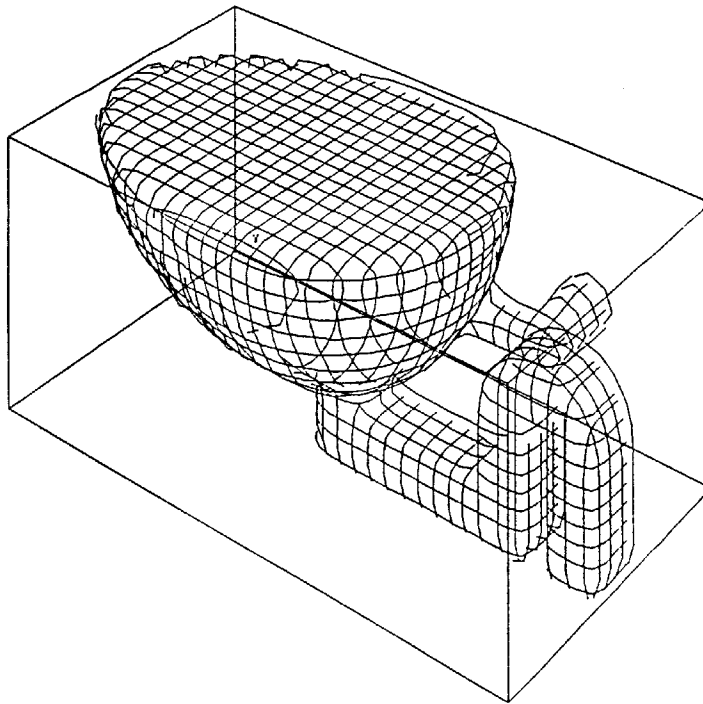

Fig. 2. Perspective plot of complete loo geometry.

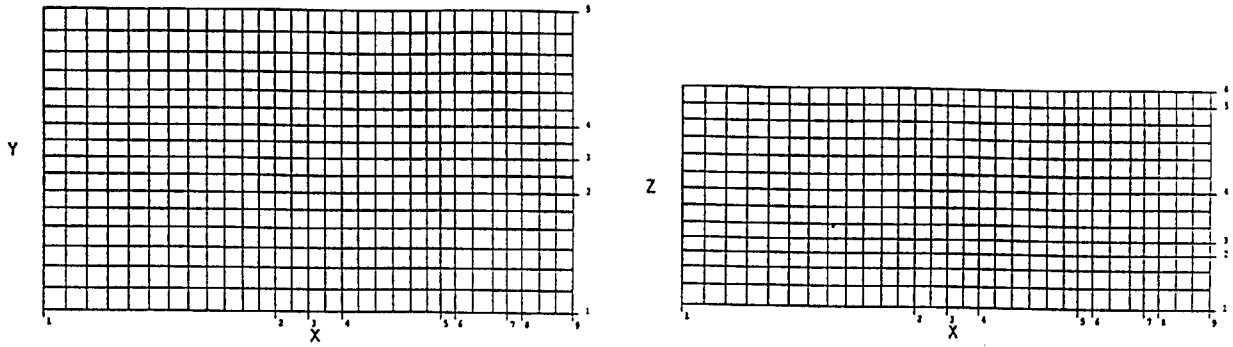

Fig. 3. Mesh used for calculations.

```

LOO TEST #6 (INITIAL PARTICLES SETUP TEST)
$XPUT
REMARK='UNITS ARE IN/S/PSI',
ITB=1, IFFK=2, ITHAX=200,
EPSI=5.0E-3, AVRCK=-2.1, PVOID=0.0,
GZ=-386.0, RHOF=9.36E-5, WF=2,
WL=2,
TIMBCT(1)=0.0, TIMBCT(2)=0.1, TIMBCT(3)=2.1,
TIMBCT(4)=2.2, TIMBCT(5)=2.5, TIMBCT(6)=2.6,
WR=5, PBCT(4,2)=-0.2, FBCT(5,2)=-0.2,
PBCT(6,2)=0.0, FBCT(1,2)=0.0, FBCT(3,2)=0.0, FBCT(4,2)=0.0,
FBCT(2,2)=0.0, FBCT(3,2)=0.0, FBCT(6,2)=0.0,
FBCT(5,2)=0.0, VBCT(1,4)=0.0, VBCT(2,4)=-15.0, VBCT(5,4)=-15.0,
WBK=6, VBCT(3,4)=-15.0, VBCT(4,4)=-15.0, VBCT(6,4)=0.0,
WB=6, WBCT(1,5)=0.0, WBCT(4,5)=0.0,
WBCT(2,5)=15.0, WBCT(3,5)=15.0,
AUTOT=2.0, PRDPT=100.0, PLTDT=0.50, TWFIN=6.0,
DELT=0.2, JBKPR=2, KTPR=2,
IRPR=2,
$SEND
$SMESH
NXCELT=29,
PX(1)=-8.0, PX(2)=-1.0, PX(3)=0.0, PX(4)=1.0,
PX(5)=4.0, PX(6)=4.43, PX(7)=6.0, PX(8)=6.43,
PX(9)=8.0, NXCELL(4)=6, SIZEX(6)=0.53, SIZEX(8)=0.52,
NYCELT=16,
PY(1)=-4.5, PY(2)=-1.0, PY(3)=0.0, PY(4)=1.0,
PZ(1)=-7.0, PZ(2)=-5.43, PZ(3)=-5.0, PZ(4)=-3.57,
PZ(5)=-1.0, PZ(6)=0.0,
$SEND
$SOBS
NOBS=1,
IOFO(1,1)=1, CX2(1)=-506.25, CY2(1)=-1600., CZ2(1)=-1296., CC(1)=32400.,
XH(1)=0.0,
IOFO(2,1)=2, CX2(2)=-506.25, CY2(2)=-400., CZ2(2)=-324., CC(2)=8100.,
XL(2)=0.001,
IOFO(3,1)=3, IOH(3)=0, CY2(3)=1.0, CC(3)=-1.0, ZH(3)=-4.0,
CX2(3)=1.0, XH(3)=1.1, YL(3)=-1.1, YH(3)=1.1,
XL(3)=-1.1, IOFO(4,1)=4, IOH(4)=0, CY(4)=1.0, XL(4)=0.0,
CC(4)=-1.0, YL(4)=-1.0, ZH(4)=-5.43,
IOFO(5,1)=5, IOH(5)=0, XL(5)=4.43, XH(5)=7.99,
CC(5)=-1.0, CY(5)=1.0, ZL(5)=-5.44, ZH(5)=-3.57,
YL(5)=-1.0, IOH(6)=0,
IOFO(6,1)=6, CX(6)=-12.43, CX2(6)=1.0, CZ(6)=7.67,
CX2(6)=1.0, XH(6)=7.99,
CC(6)=50.323, XL(6)=4.43, XH(6)=7.99,
YL(6)=-1.0, YH(6)=1.0, ZL(6)=-3.57, ZH(6)=-2.0,
IOFO(7,1)=7, CY(7)=1.0, YL(7)=-1.0, ZH(7)=-3.57,
CC(7)=-1.0, XH(7)=6.43,
XL(7)=6.0,
IOFO(8,1)=8, CY2(8)=-1.0, CC(8)=1.0,
CX2(8)=-1.0,
XL(8)=-1.1, YL(8)=-1.1, YH(8)=1.1, ZH(8)=-6.999,
IOFO(9,1)=9, CZ(9)=1.0, YL(9)=1.51, IOFO(10,1)=10, CC(10)=-0.1, XL(10)=4.0, XH(10)=5.08, YL(10)=2.58,
CZ(9)=3.093, YH(9)=2.59, IOH(10)=0, ZL(10)=-4.047, XH(9)=5.08, ZH(9)=-3.0, ZH(10)=-3.0,
$SEND
$FL
FLHT=-3.57,
NFLS=2,
FCC(1)=-0.1, FCC(2)=-0.1289,
IFDIS(2)=2,
FIOH(1)=0, FYL(1)=-1.0, FYH(1)=1.0, FZH(1)=-3.0,
FYL(1)=-6.2, FCZ(2)=-0.0361, FZH(2)=-3.57,
$SEND
$SBF
$SEND
$TEMP
$SEND
$SHOTN
$SEND
$GRAPHIC
NPVPLTS=3,
YV1(1)=0.01, YV2(1)=0.01, Xv1(2)=-0.01, Xv2(2)=-0.01,
ZV1(3)=-3.5, ZV2(3)=-3.5,
NSPLTS=3, NVEWS=2,
KONTFS(1)=2, ISVEW(1)=2, ISVEW(3)=2,
KEA(1)=-40., YEA(1)=-50., ZEA(1)=35.0,
KEA(2)=-40., YEA(2)=50., ZEA(2)=15.0,
KOBST=8, KOBST=11, IOBSL=15, IOBSR=17,
ILOC(1)=21, JLOC(1)=14, KLOC(1)=9,
NPPLTS=1, IPVEW(1)=2, IPERP(1)=4,
$SEND
$PARTS
IPPKT=0, NUP=0.05, NPZ=6,
NFX=20, NPY=15, NPY=15, YPF=-3.0, YPBK=3.0,
XPL=-5.5, XPR=2.4, ZPT=-3.57,
ZPB=-5.43,
$SEND

```

Fig. 4. FLOW-3D input file for loo problem.

